



BJB26PD

PNEUMATIC JACKING BEAM

TECHNICAL SPECIFICATION

The Boston BJB26PD is our mid-range model of slim line jacking beams. Built with strength and simple installation in mind, and with a closed height of just 180mm, it is ideal for working on vehicles with very low clearance.

Compact and lightweight, the BJB26PD can easily be fitted to most lifts and inspection pits. A wide range of mounting arms are available and any specific / custom requirements can always be met. The beam is efficient and quick to operate, and uses a pneumatic over hydraulic double-action pump for a fast lifting time. The adjustable top support beam can extend up to 1610mm covering most wide chassis vehicles and a separate extra-width kit is also available. For optimum safety, the beam employs a two-hand lowering system with dead man's release, an automatic safety locking device which engages during the raising of the beam and a hydraulic safety overload valve.

Main Features

- Innovative design and compact structure
- Low closed height of just 180mm
- Extendable top arm to 1610mm
- Unique adjustable support arms to fit lifts and pits
- Two hand lowering operation
- Pneumatic operation with fast lifting time
- Automatic safety locking device
- Safety overload valve
- Supplied with three sets of height extensions (*)
- Supplied with protective rubber lifting cushions

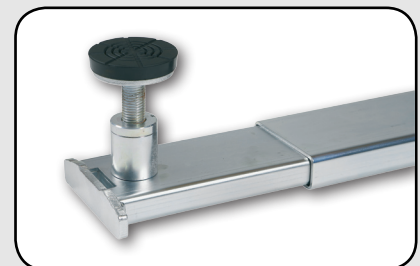
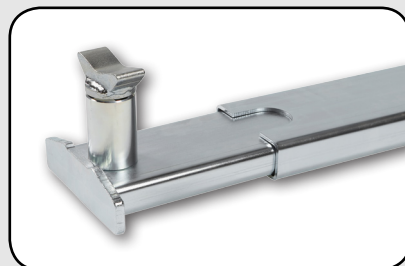
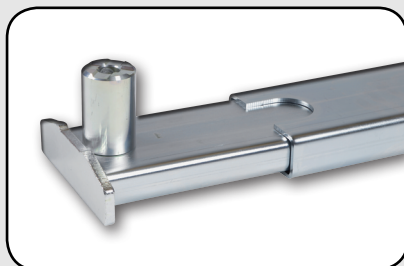

for any further information or advice,
please contact our sales team.
time is never an issue - customer service is.

0800 085 0620
www.boston-ge.com sales@boston-ge.com

Technical Specification

- Product Code: BJB26PD
- Max Capacity: 2.6T
- Stroke: 250 mm
- Extending Arms: 780 - 1619 mm
- Lifting Frame Height: 120 mm
- Lifting Frame Depth: 249 mm
- Min Height (Closed): 180 mm
- Width (with arms): 780 - 1180 mm
- Weight: 105 kg
- Operating Pressure : 8.5 bar

Standard Configuration

- Jacking Beam main lifting frame
- Jacking Beam top beam with extensions
- Mounting arms to suit Boston B461 four post lift
- Three sets of height extensions (10 / 40 / 85 mm)
- Protective rubber cushions

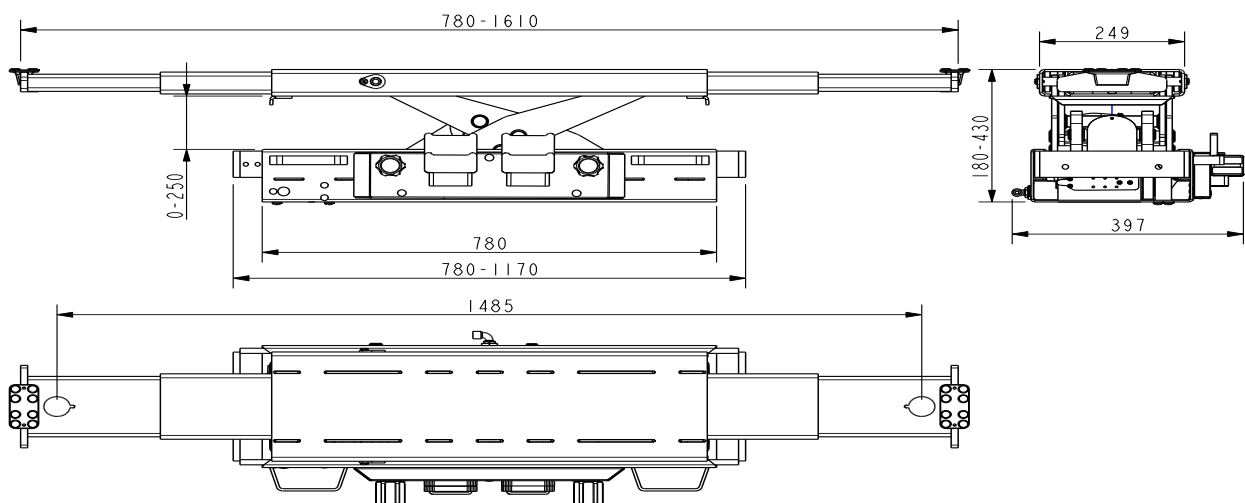

for any further information or advice,
please contact our sales team.
time is never an issue - customer service is.

0800 085 0620
www.boston-ge.com sales@boston-ge.com